

FABRİKA GÜNLÜKLERİ

Guy Delisle

Çeviri: Kerem Yalçın

© **KARAKARGA YAYINLARI 378**

*Her hakkı saklıdır. Bu eserin aynen ya da özet olarak hiçbir bölümü,
telif hakkı sahibinin yazılı izni alınmadan kullanılamaz.*

Açıklama:

Quebec'te bu kitaptaki gibi fabrikalardan hamur ve kağıt fabrikası diye bahsedilir. Bu fabrikalar hem kağıt hamuru hem de kağıt üretmektedir. Yani bunlara kısaca hamur ve kağıt fabrikası denmektedir.

FABRİKA GÜNLÜKLERİ

Guy Delisle

Genel Yayın Yönetmeni: Mustafa Kutlukhan Perker

Editör: Neslihan Perker

Çeviri: Kerem Yalçın

Dizgi: Emirhan Perker

Orijinal Adı: Chroniques de Jeunesse

Chroniques de Jeunesse by **Guy Delisle**

<https://www.guydelisle.com/>

©Editions Delcourt, 2021

Bütün hakları saklıdır.
Akan Ajans aracılığıyla alınmıştır.

I. Baskı: Şubat 2022

ISBN:978-625-7217-95-8

*İmtiyaz Sahipleri: Yelda Cumaloğlu, Mustafa Kutlukhan Perker
KaraKarga Yayınları, Destek Yayınları'nın alt kuruluşudur.*

Yayıncı Sertifika No. 13226

Adres: Abdi İpekçi Cad. No. 31/5

Nişantaşı / İstanbul

Tel. (0 212) 252 22 42

Faks: (0 212) 252 22 43

 karakarga.com  info@karakarga.com
 karakargayayinlari  karakargayayinlari
 karakargayayin

Baskı: Deniz Matbaa Mücellit

Adres: Maltepe Mahallesi, Hastane Yolu Sokak

No. 1/6 Zeytinburnu - İstanbul

Tel. (0 212) 613 30 06

Matbaa Sertifika No. 48625



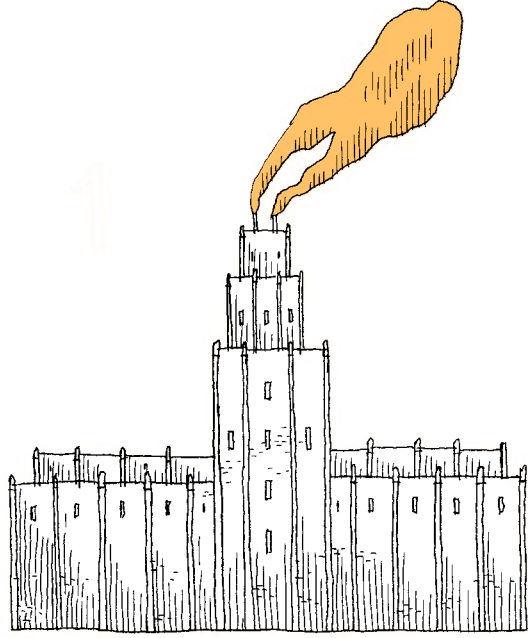

İKİMİZ
İÇİN.

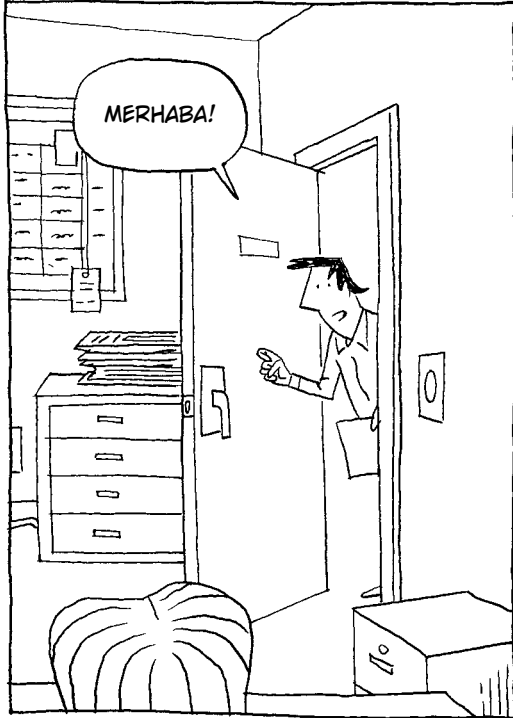
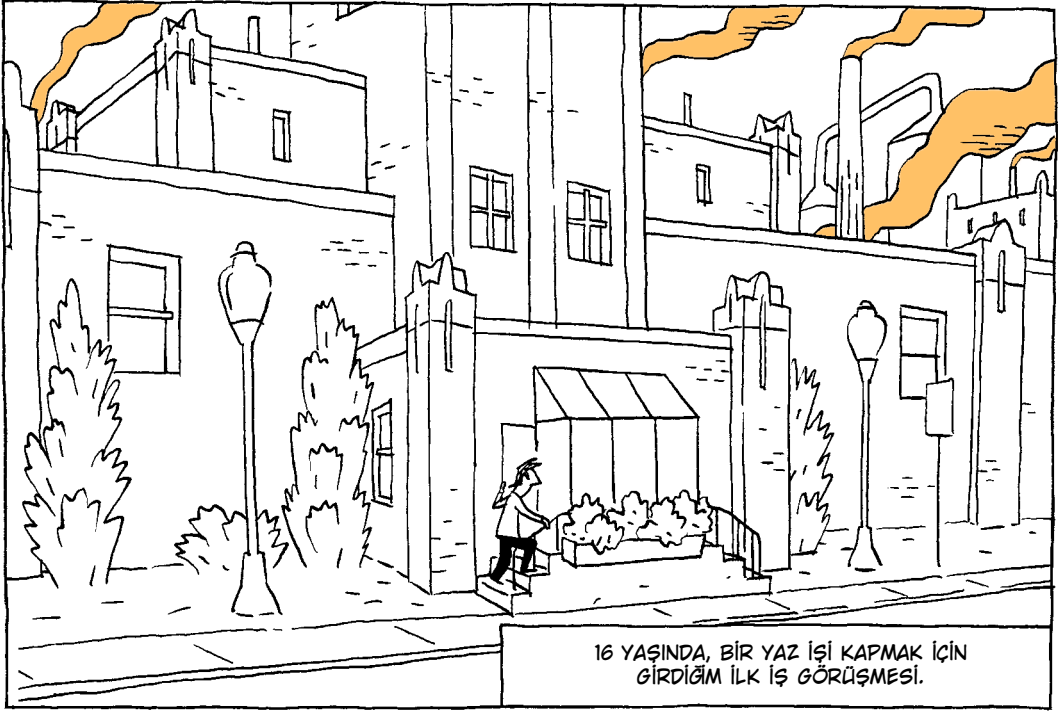

BABAM 30 YILDIR BU FABRİKADA
ÇALIŞTIĞINDAN ŞANS MELEKLERİ BENİM
YANIMDA.



HER ŞEY İYİ GİDİYORDU, TA Kİ MÜDÜR
ŞUNU DİYENE KADAR:

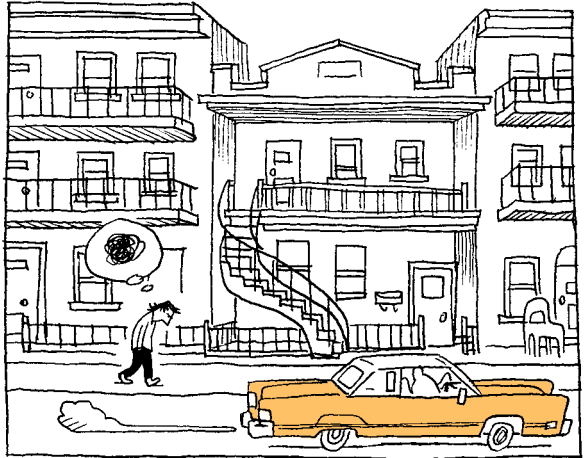

BİR YÜZÜ ESKİ ŞEHRE DÖNÜK, SAINT-CHARLES
NEHRİ'NİN KIYISINA UZANMIŞ...

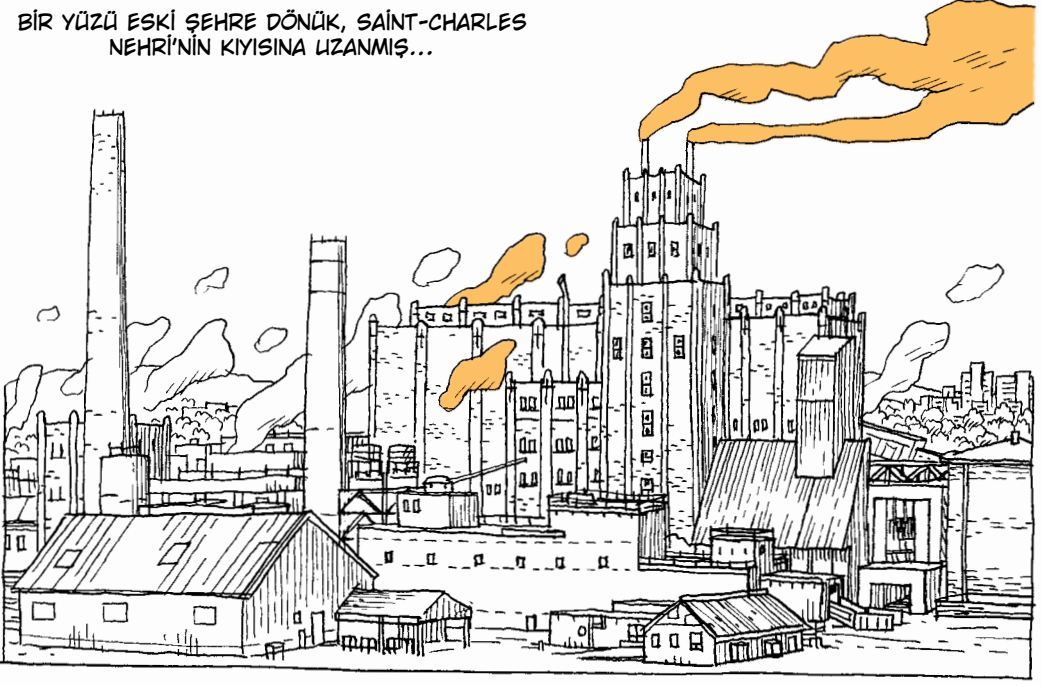

BACALARINDA DUMANI HER DAİM
TÜTEN QUEBEC HAMUR VE KAĞIT
FABRİKASI'NI GÖRMEMEK NE
MÜMKÜN.

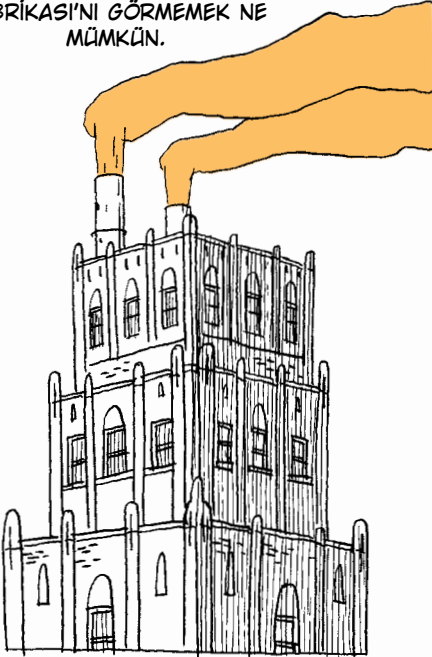

GÖRMEDİYSENİZ DE RÜZGAR TERS YÖNDEN
ESTİĞİNDE, O SİZE KENDİSİNİ KESKİN KÜKÜRT
KOKUSUYLA MUTLAKA HİSSETTİRİR.

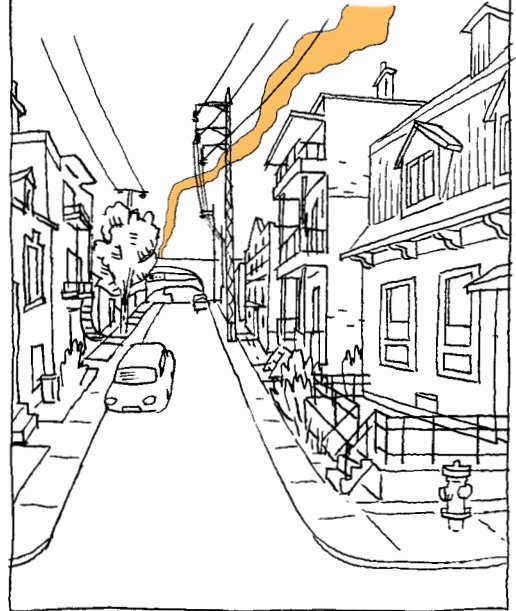

İŞTE, 1927 KURULUŞ TARİHLİ
ANGLO-CANADIAN
PULP AND PAPER MILLS, KISACA ANGLO.
(İNGİLİZ-KANADALI)

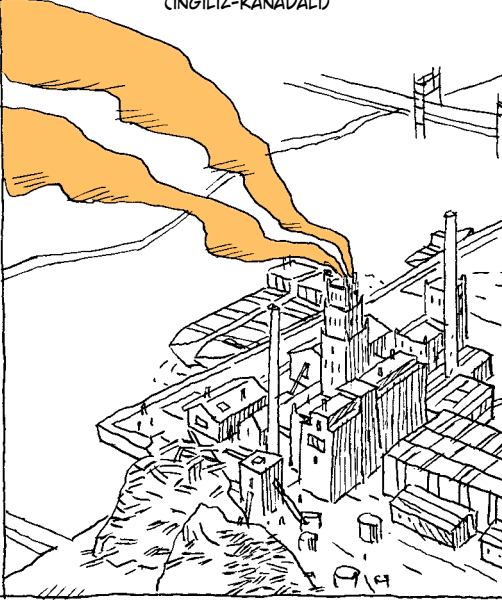

1975'TE, SAHİBİ ALBERT EDWIN REED'DEN
DOLAYI REED PAPER İSMİNDE.
(İNGİLİZ)



1988'DE (JAPONLARLA) DAISHOWA...

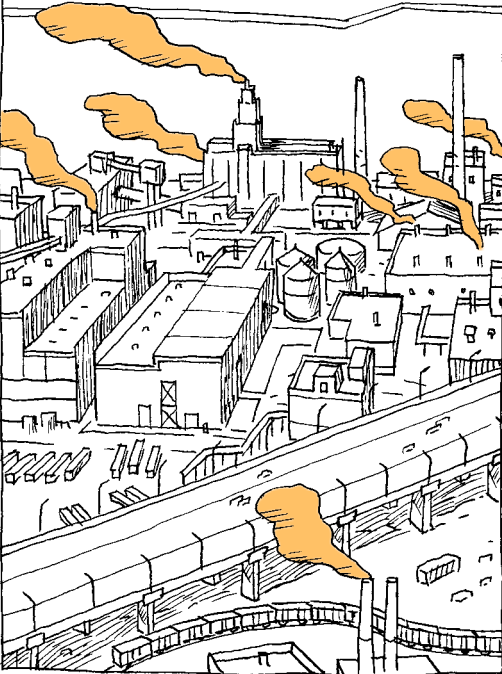

2001'DE STADACONA KAĞITLARI
(AMERİKAN)

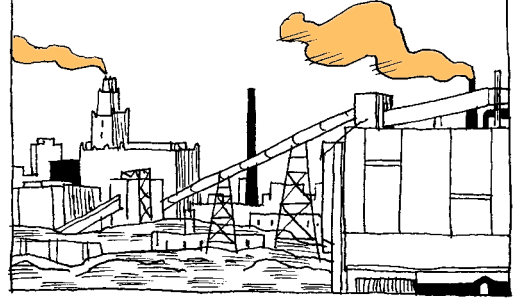

VE 2004'TEN BERİ DE WHITE BIRCH.
(AMERİKAN)

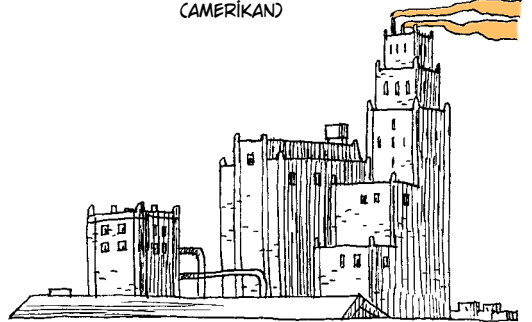

ANGLO, REED, DAISHOWA... BABAMIN İŞ YERİNİ
TARİF ETMEK İÇİN SİRASIYLA TÜM BU İSİMLERİ
KULLANDIĞINA ŞAHİT OLDUM.

BABA-
MIN
EVI.

BEN SENİN
YAŞIN-
DAYKEN...

AMA GENELDE, "TÜKKAN" DERDİ...

HER
ZAMAN
AYNI
ŞEY...

TÜKKANDAKİ
ELEMANLAR
SONLUDA
GİTTİĞİMİ
GÖRMEK
İSTİYORLAR...

AMA SANA
ŞUNU SÖYLE-
YİYİM...

YA DA "DEĞERMEN"

BU YENİ
MAKİNA-
LARLA...

DEĞERMANDE
GİTTİKÇE DAHA
FAZLA GERİ
DÖNÜŞÜM
YAPILIYOR.

ESKİDEN
BÖYLE
DEĞİLDİ.

MERHABA.

İŞÇİLERİN GİRİŞİ NE
TARAFTA?

İLK GÜN.

EN
DİPTE!

BUYURUN.

BENİM YAŞLARIMDA BAŞKA İKİ ÇOCUK DAHA İŞ GÜVENLİĞİYLE İLGİLİ BİR VIDEO İZLİYOR.

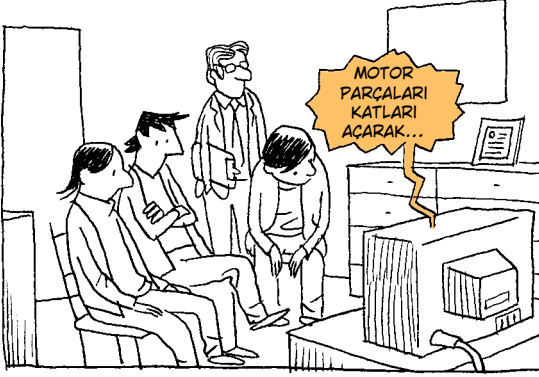

ORADAN AYRILIP BİR ŞÖRT VE BOTLARIMI GIYMENK ÜZERE SOYUNMA ODASINA GEÇİYORUM.



'MAKİNE DAİRESİ'NE GEÇERKEN STAJIMDA BENİMLE İLGİLENECEK 30'LU YAŞLARDA İRİ YARI BİR ELEMANLA TANİŞTİRİLİYORUM.

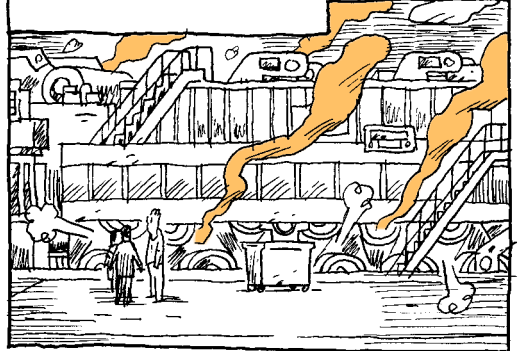

SEMPATİK BİR TİP AMA BANA GÖRE BİR AZ FAZLA SICAKKANLI.



ALTINCI KOLDAKİ KAĞIT MAKİNESİYLE İLGİLENECEĞİM.



GÖRECEKSİN,
OLDUKÇA
KOLAY!

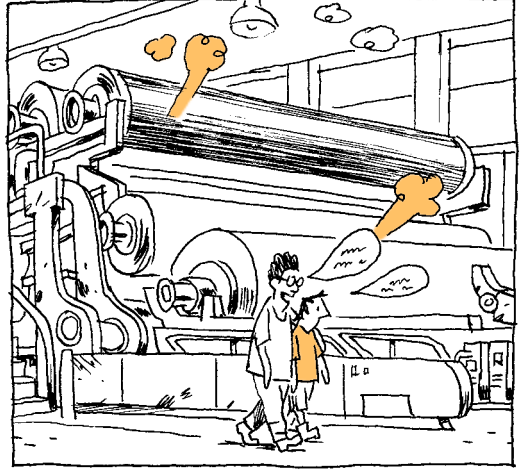

DÖRT KOCA MAKİNE, TÜM GÜN, 24 SAAT BOYLUNCA "NEW YORK TIMES" GİBİ MÜŞTERİLERE GAZETE KAĞIDI TEDARİK ETMEK İÇİN LOKOMOTİF GİBİ ÇALIŞIYOR.

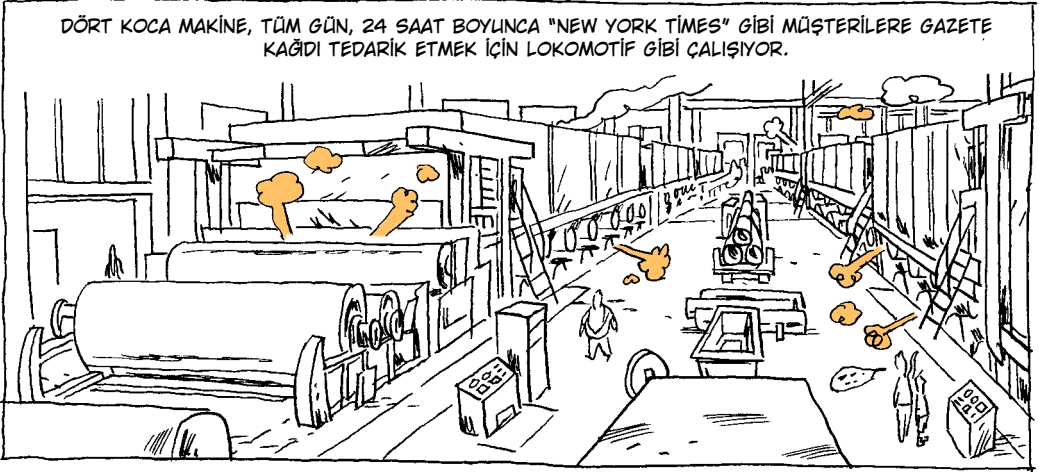

KABACA, BURADA AĞAÇ KÜTÜKLERİ SIRASILA EZİLİP, KURUTULDUKTAN SONRA DEVASA SİLİNDİRLERE SARILACAK BİR HAMLURA DÖNÜŞÜYOR

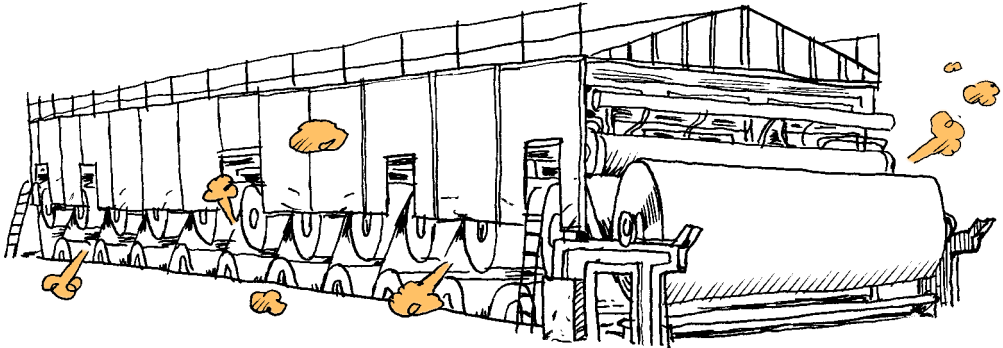

İKİNCİ BİR ALET İSE KAĞDI SARIP MÜŞTERİNİN İSTEĞİNE GÖRE DAHA KOMPAKT BİR ŞEKİLDE PARÇALARA AYIRIYOR.

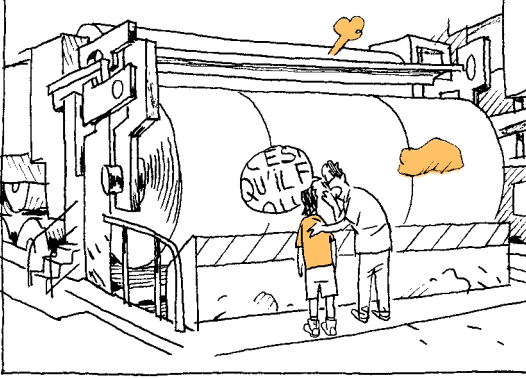

SANIRSIN Kİ SAUNADAYIZ...



HATTA O KADAR GÜRÜLTÜLÜ Kİ HER ZAMAN KULAK TIKACI TAKIYORUZ.



BAZI ESKİ ELEMANLARIN BU DURUMLA BİR ALIP VEREMEDİKLERİ YOKTU.

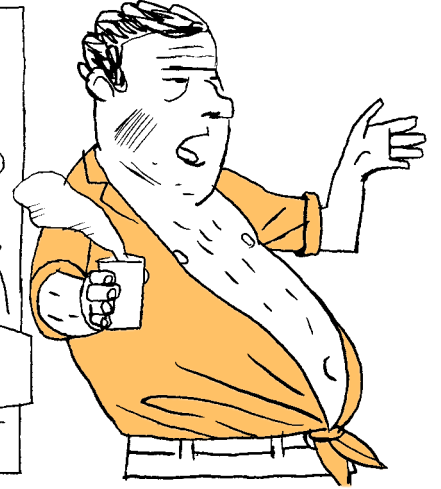
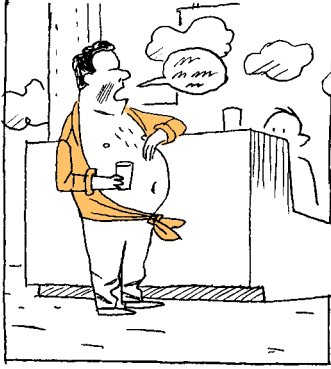

BENCE BUNLAR ARTIK TAMAMEN SAĞİR OLMUŞLAR

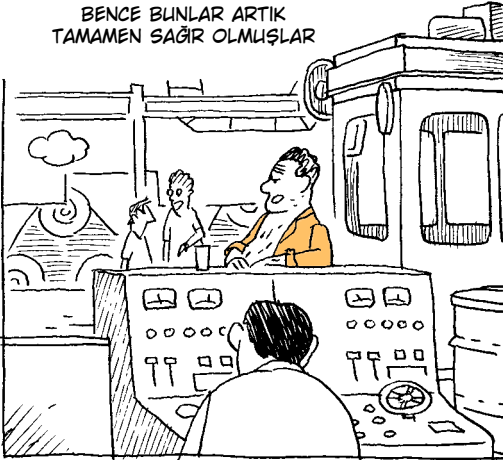

İŞÇİLER İÇİN HAFTALIK MESAI 12 SAATLİK DÖRT GÜNE AYIRILIYOR.

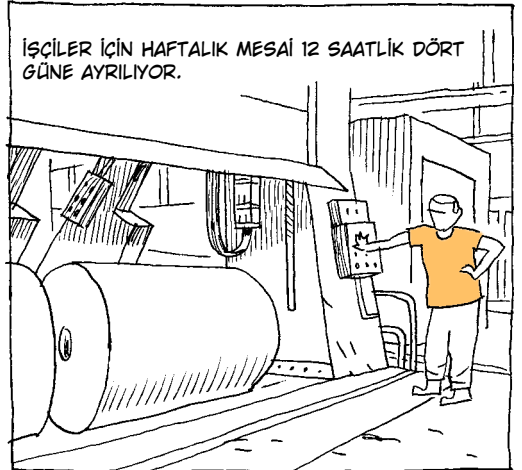

BU ÇALIŞMA DÜZENİ SENDİKANIN PAZARLIĞIYLA ELDE EDİLMİŞ. ELEMANLAR HAFTA SONU İÇİN FAZLADAN BİR GÜN DAHA GEÇİRMİYİ TERCİH EDİYORLAR.

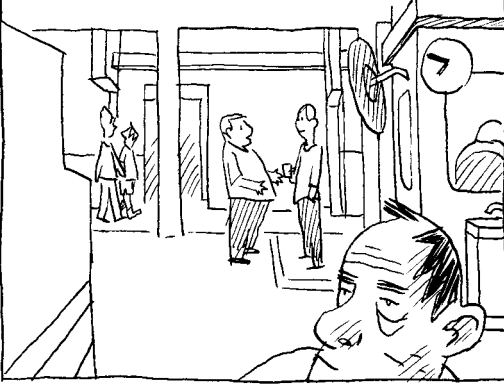

YANI AKŞAM SAAT 7'DEN SABAH SAAT 7'YE 12 SAAT BURADAYIZ.

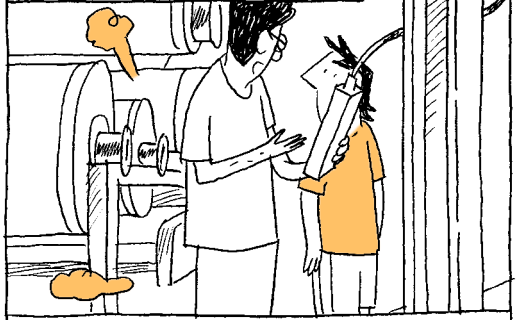

İLK GÜN İÇİN ÖNÜMDE 11 SAAT DAHA VAR KI BENCE BU BİLE FAZLA.

VİNCİ KULLANMAYI ÖĞRENMEKLE BAŞLIYORUM.

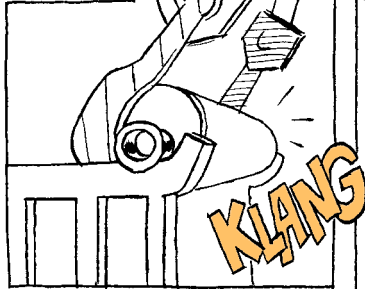
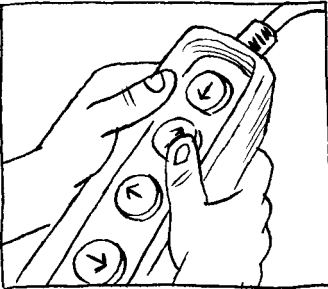
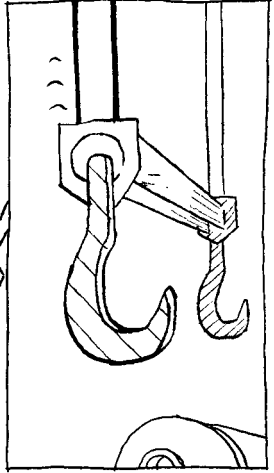
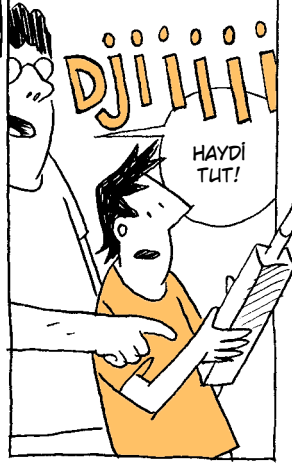
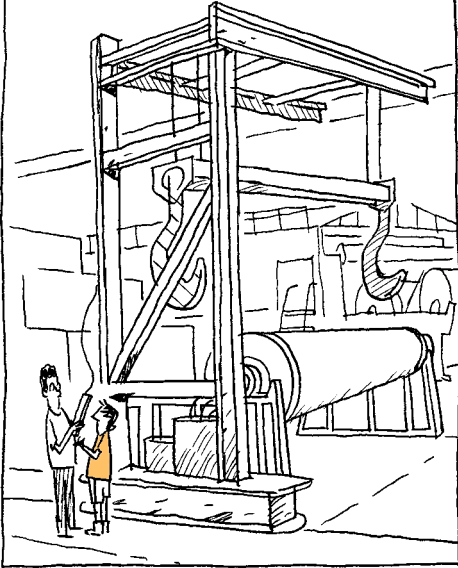

BÖYLE BİR KÜTLEYİ HAREKET
ETTİRMEK İÇİN ADIM ADIM
İLERLEMELER GEREKİYOR.

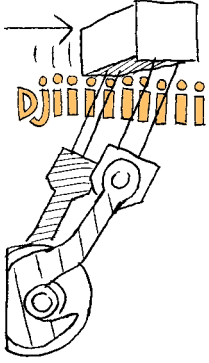

← MESELA
SİLİNDİRİ BU
NOKTAYA
GETİRMEK
İÇİN...

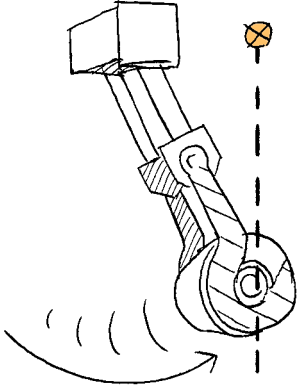
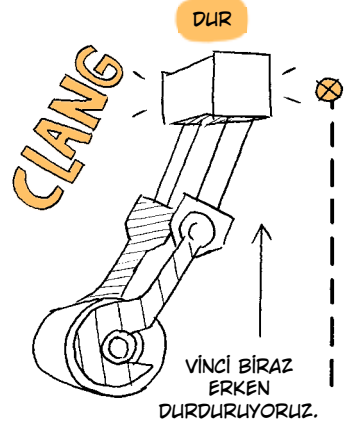

DÜRDÜRÜLÜNCE
SİLİNDİR
SALLANIYOR.

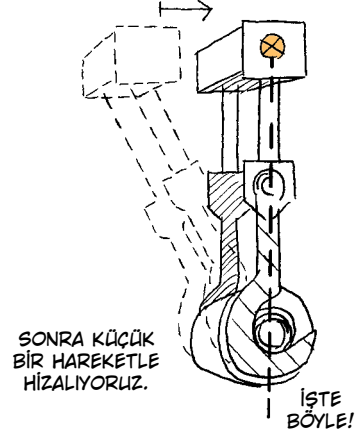

SONRA KÜÇÜK
BİR HAREKETLE
HİZALİYÜZ.

İŞTE
BÖYLE!

BU İŞİN EĞLENCELİ KISMI.

Djiiiiiiii



BİR DE MAKİNENİN GEÇTİĞİ KORİDORU BASINÇLI HAVAYLA
TEMİZLEME KISMI VAR.



MAKİNE SÜREKLİ TAKILIYOR VE
KAĞIT PARÇALANIYOR.

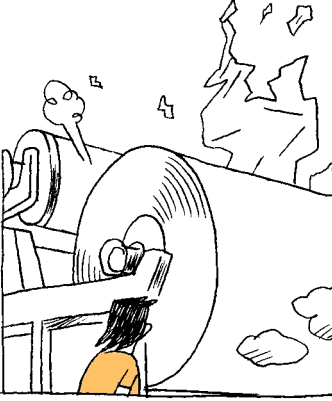

MOTOR DURANA KADAR NEW YORK TIMES'İN TEK BİR SAYISINA
YETECEK KADAR KAĞIT ETRAFA SAVRULUYOR.

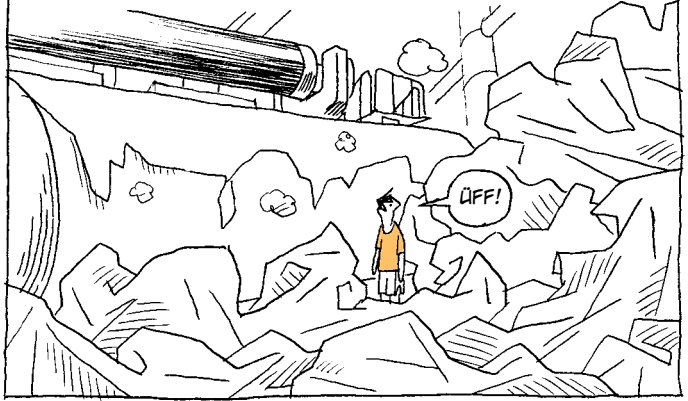

BU DURUMDA BASİT BİR TAHTA İTTİRGEÇ
KULLANARAK TÜM BUNLARI MAKİNELERİN ALTINDA
BULUNAN GERİ DÖNÜŞÜME
YOLLAMAK GEREKİYOR.

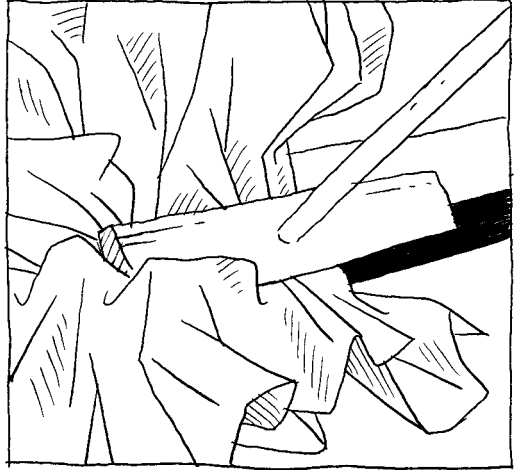

İLK GECEMDE, 12 SAATLİK VARDİYAMIN BÜYÜK ÇOĞUNLUĞUNU KİLOMETRELERCE KAĞIDI BU DELİĞE
TIKMAKLA UĞRAŞTIM.



LIFAK BİR NEFES ALMAK İÇİN MAKİNELERİN ARASINA SES YALITIMLI KABİNLER KOYULMUŞ.

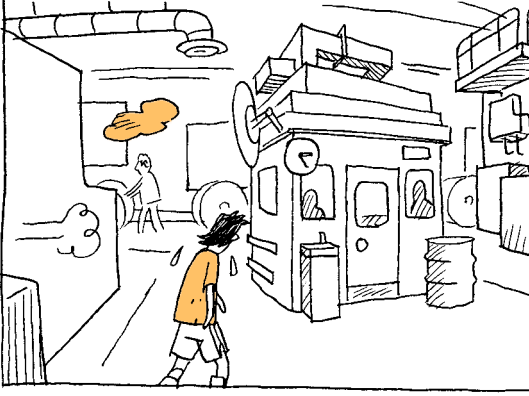

BİR KÖŞEDE TELEVİZYON, DİĞER KÖŞEDE DE BU CEHENNEMİ SALINADA HAYATTA KALMAMIZI SAĞLAYAN KLİMA VAR.



ESKİLER PANTOLON GİYERKEN GENÇLER ŞORT GİYİYOR.



BU SICAKTA NASIL PANTOLONLA DURULUR ANLAMİYORUM.



BU KADAR TAKILMA YAHU, BURADA HEPİMİZ ERKEK ERKEĞEYİZ.



BURAYA İLK BAŞLADIĞIMDA BİR İB.E 'ORDUSU'NUN ARASINA DÜŞTÜĞÜMÜ SANMIŞTİM.

